

ABS SUBMERSIBLE MIXER RW 200 AND 280



50 Hz AND 60 Hz

Compact ABS submersible mixer for flushing and cleaning of pump sumps plus a wide range of applications in sewage treatment plants and in industrial mixing applications.

Applications

The compact ABS submersible mixers of the RW 200 and 280 series have been designed for a wide range of applications. Apart from the use in pump sumps – avoidance of deposits and floating crusts – the units are also ideal for a variety of mixing and stirring applications in sewage treatment plants and in industrial areas. Depending on the intensity of mixing required and the flow formation needed, one or more mixers may be installed. It is suitable for cleaning sumps up to 5 m (16 feet) diameter.

For optimum selection in general mixing applications we require the following information:

- application
- tank/sump dimensions
- medium to be mixed
- viscosity, specific weight of medium
- temperature, dry matter content, etc.

Construction

Motor

The water pressure-tight encapsulated modular motor with cast iron housing, oil chamber and propeller form, together with the bracket, a compact robust unit construction.

Motor: Three-phase, 4-pole, 1450 min⁻¹ (50 Hz), 1750 min⁻¹ (60 Hz), (single-phase versions in 60 Hz), insulation class F, protection class IP 68.

Bearings

Rotor shaft supported in lubricated-for-life ball bearings. Tandem shaft sealing with lip seal and silicon carbide mechanical seal.

Solids deflection ring

The patented solids deflection ring protects the mechanical seal from damage by ingress of solid or fibrous matter.

Propeller

Blockage-free propeller which will not be clogged by trash is manufactured in cast iron. The optimum installation position for the particular application can be achieved quite simply. The mixer bracket allows a selection of various angles in the vertical plane. Swivelling in the horizontal plane is facilitated by the conical threaded pipe connection.

TCS-Thermo-Control-System

With thermal sensors in the stator to give a warning and switch off the unit if excessive temperatures are reached in the motor.

Identification code	RW	20	22	13 /4	Ex
Hydraulics					
Mixer series _____					
Propeller diameter [cm] nominal _____					
Propeller type _____					
Hydraulic No. _____					
Motor					
Motor power P ₂ [kW] x 10 _____					
Number of poles in motor _____					
Motor version: Ex (only on request) _____					

Materials

Motor housing _____ Cast iron EN-GJL-250 (ASTM A-48 Class 40)
 Motor shaft _____ Stainless steel 1.4021 (AISI 420)
 Oil chamber _____ Cast iron EN-GJL-250 (ASTM A-48 Class 40)
 Propeller _____ Cast iron EN-GJL-250 (ASTM A-48 Class 40)
 Fasteners _____ Stainless steel 1.4401 (AISI 316)



- Easy installation
- Small space requirements
- Adjustable bracket allows direction to be altered
- Guide rail mounting option
- Cast iron housing
- Wear-resisting propeller
- High power reserves
- Patented solids deflection ring
- Modular motor

Installation Examples in a Pump Sump

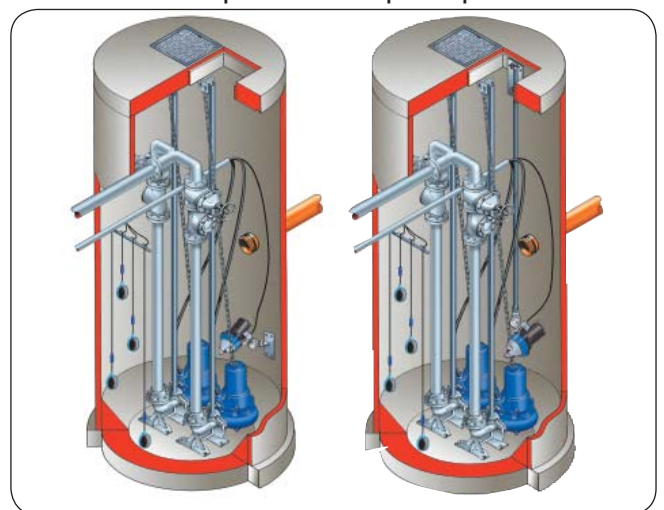

ABS SUBMERSIBLE MIXER RW 200 AND 280

Technical Data

Type	Motor		Propeller			Speed min ⁻¹	Motor power*			Rated voltage				Weight kg/lb	
	Hz	Ph	Diam. mm	Diam. ins	Angle degree		P ₁ kW	P ₂ kW	P ₂ hp	230 V A	400 V A	460 V A	575 V A		
RW 2022	S13/4	50	3	200	8"	16	1450	1.9	1.3	1.7	6.3	3.6			26/57
RW 2022	S16/4	60	3	200	8"	16	1750	2.2	1.6	2.1	7.2		3.6	2.9	26/57
RW 2022	S18/4	60	1	200	8"	16	1750	2.6	1.8	2.4	12.1				32/70
RW 2822	S25/4	50	3	280	11"	16	1450	3.3	2.5	3.4	10.1	5.8			32/70
RW 2821	S28/4	60	3	250**	9.8"	16	1750	3.6	2.8	3.8	10.9		5.5	4.4	32/70

* P₁ = Power taken from mains; P₂ = Power at motor shaft; **The type designation remains RW 28..

An adjustable bracket and 10 m cable (33 ft) with free cable ends supplied as standard. Cable: 7 core special submersible cable, std and ex.

Dimensions and Installation Examples

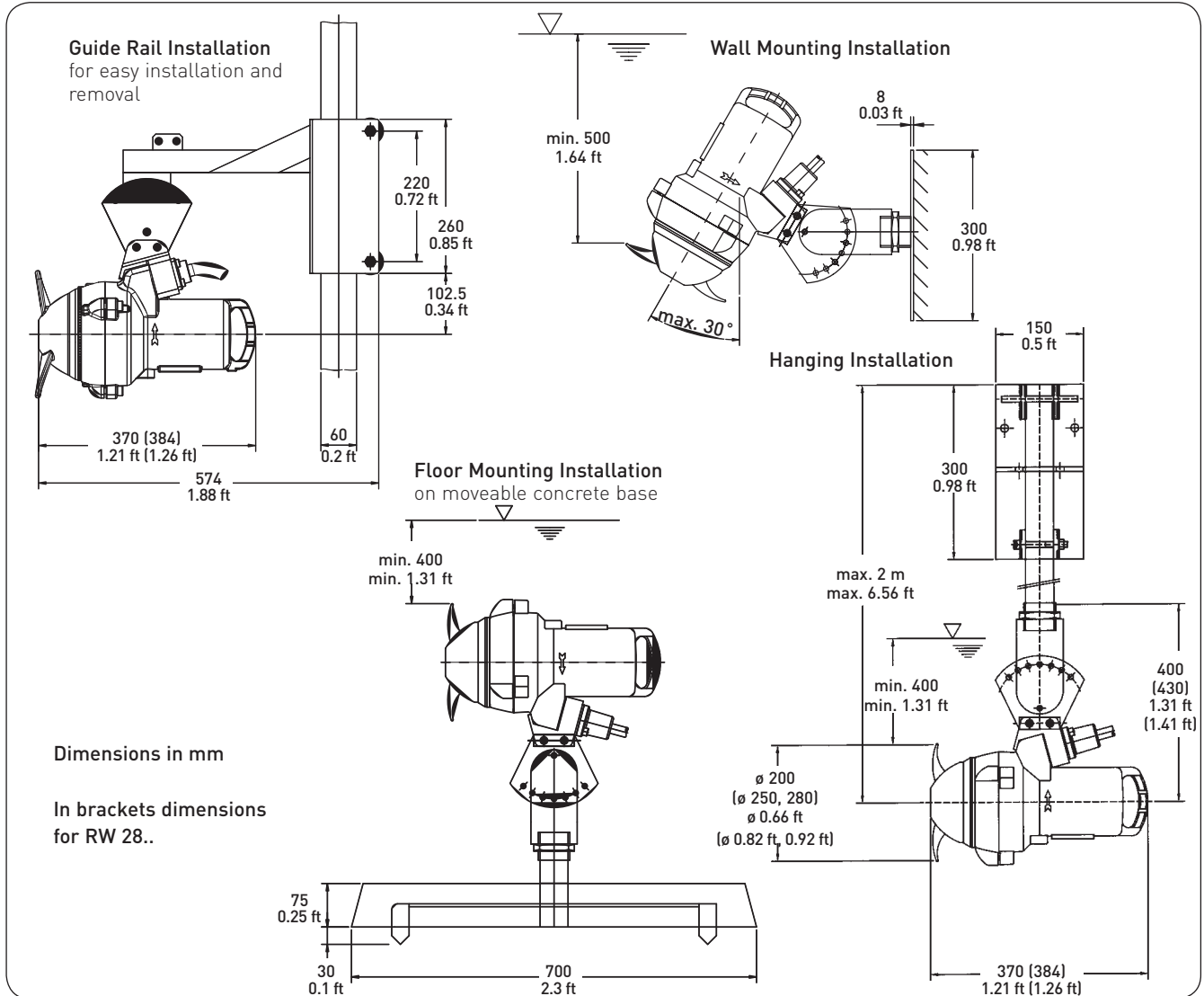

Tank Sizes

Maximum diameter
RW 200: 3.5 m (11 ft)
RW 280: 5.0 m (16 ft)



Maximum size
RW 200: 3 x 5 m (10 x 16 ft)
RW 280: 4 x 6 m (13 x 20 ft)

